

Shop Drawing

| chsong@mail.ssyenc.co.kr | 02)3433-7762

Shop drawing

가

(Engineering Drawing)
(Placing/Construction Drawing)

가

가
가

가

shop drawing

1.

: 2000

가

가

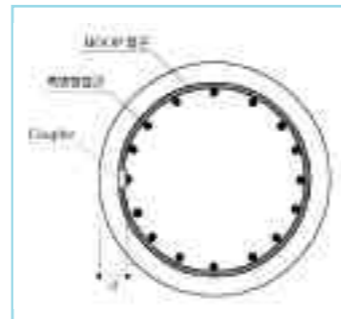

[1 - 1]

(cross tie)

가 ([1 - 1])

6d 8cm

135°

가

135° 90°

180°

([1 - 2], [1 - 3])

가

가

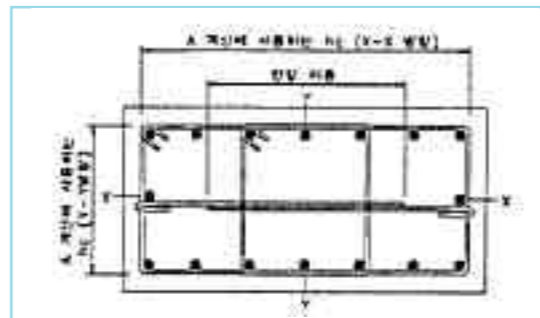

[1 - 2]

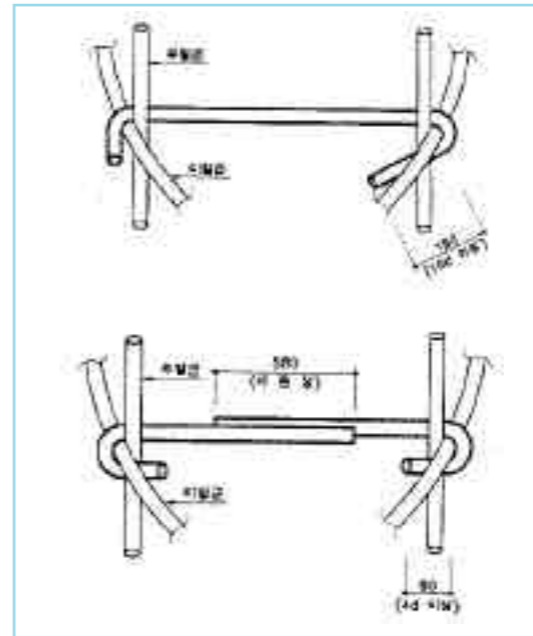

[1 - 3]

2.

2

가

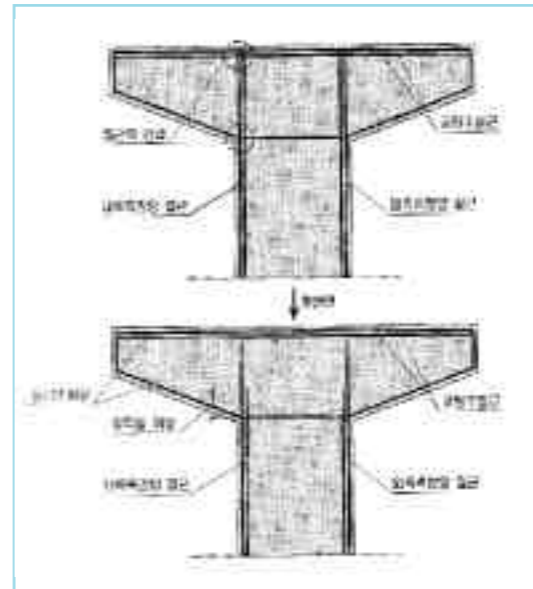

[2]

:

가 12.5cm

. T

([2])

3. PSC Beam

: Beam

가

(32mm) 가

:

([3])

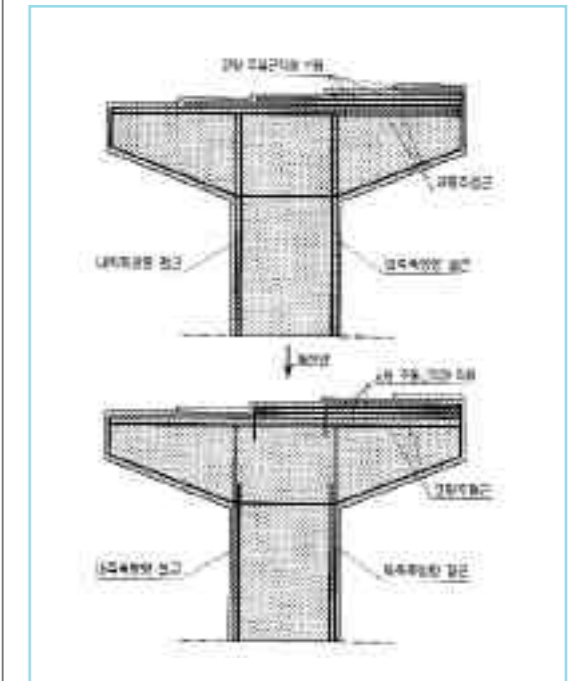

[3] PSC Beam

4.

:

(40cm)

가

:

(+10cm)

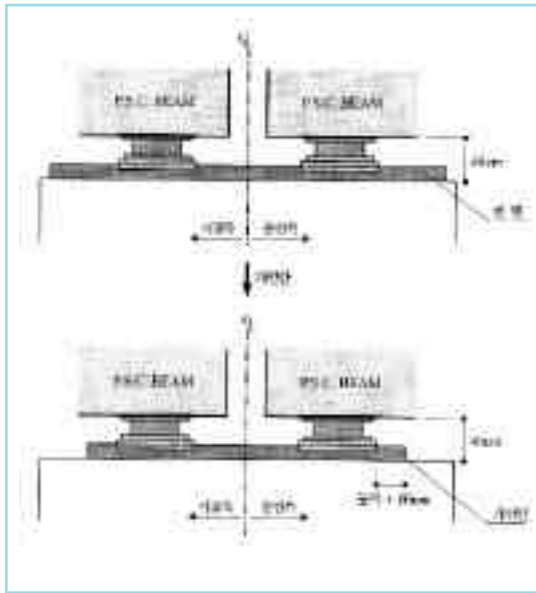

[4]

가20cm 1 ([4])

5. () : 가 ,

: 20% , 4~5m

(1) ([5 - 1])

(2) ([5 - 2])

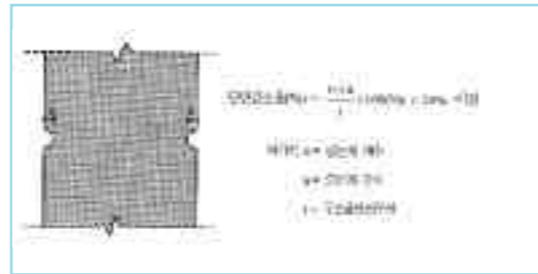

[5 - 1]

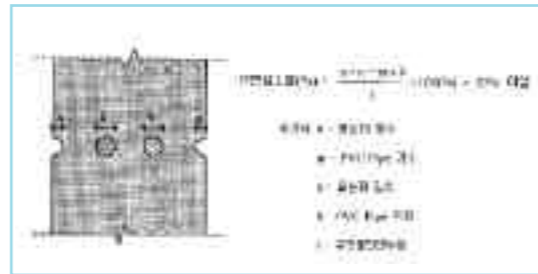

[5 - 2]

가 pvc

6. : deck finisher 가 가

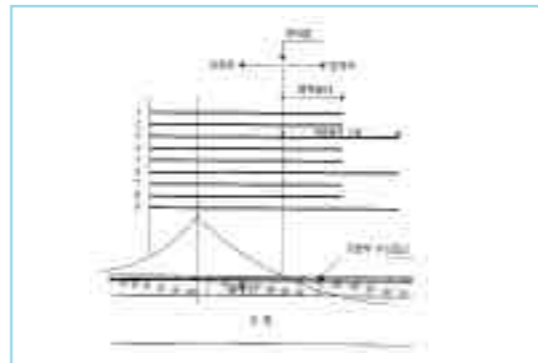

[6]

1/3 12 1/16 ([6])

7. : 가

1:3 (2%) 가

2000 (1:1) ([7])

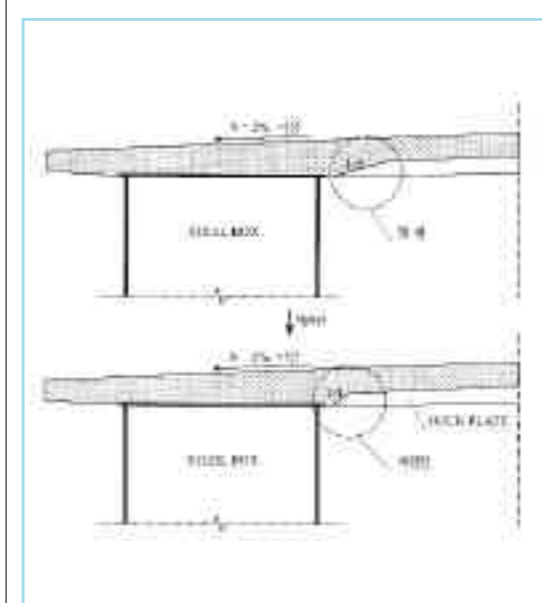

[7]

8. : 가 frame 가 ([8])

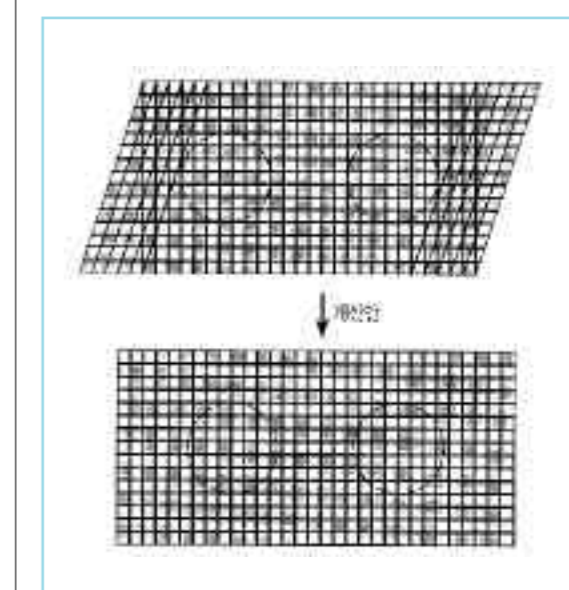

[8]

9. : 가 (1) 5m : tie bar

cut () saw
 ([9 - 1]).

(2) 5m :

([9 - 2]).

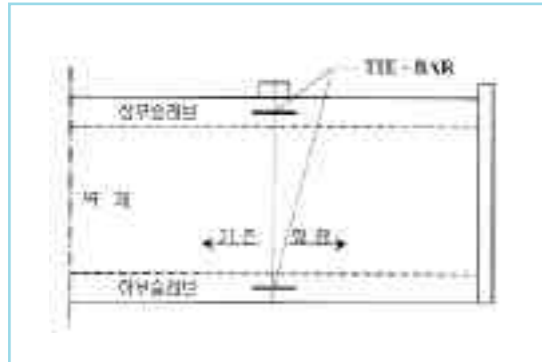

[9 - 1] 5.0m

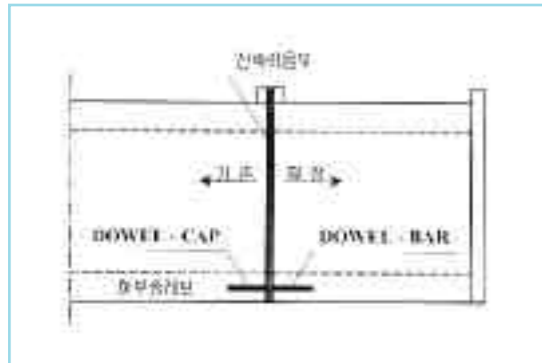

[9 - 2] 5.0m

10. (Stirrup)

U

가

(B)

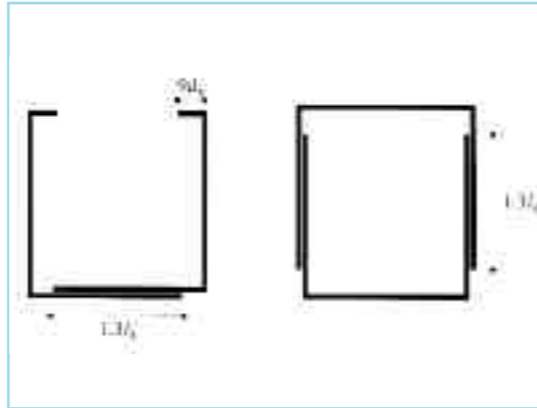

[10]

(0.9mm) ([10]).
 , 가 massive

가 ,

가 .

shop drawing

1."	"	(2000)
2."	"	(2000)
3."	"	(1998, 1999)
4."	5 "	(1999. 3)