

2000

가
가 ,
LCC(LIFE CYCLE
COST)
(: 1~3 , : 10
)
가
가
가
2000
가가
가
가
2000
가

< 1 >

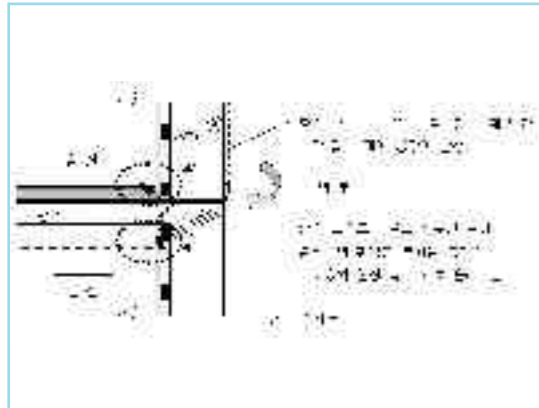



CON'C laitance
CON'C CON'C

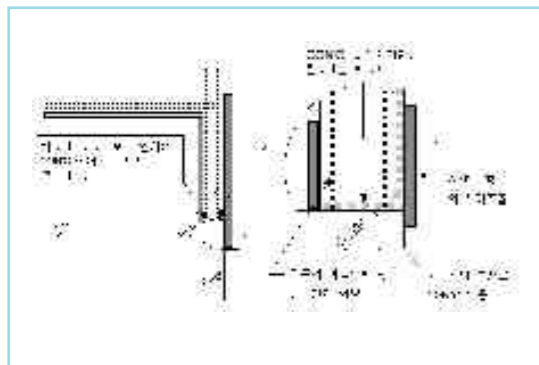

CON'C dry-out
(CON'C)
:
()
:

CON'C joint
joint
joint CON'C
FORM OIL()

()	
CON'C laitance	45%
	93%

CON'C
CON'C 가
가

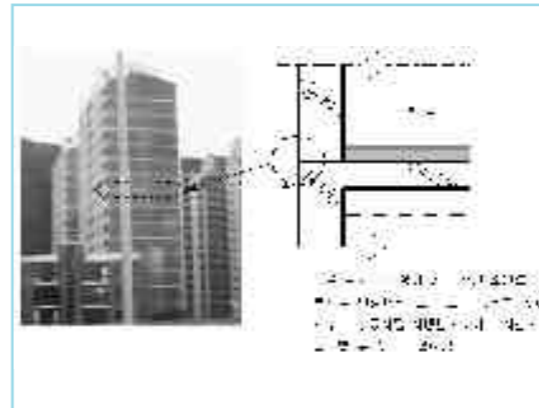
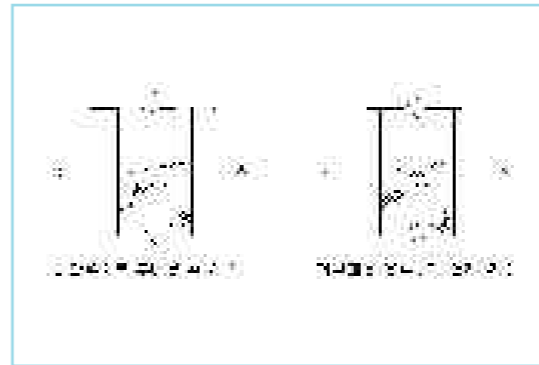

CON'C
, joint 가

< 2 >



Opening size



Opening Size

()
CON'C
가
Opening Size
() 가
:
CON'C



OPENING SIZE
(:10cm)
(CON'C SST'L-)

< 3 >

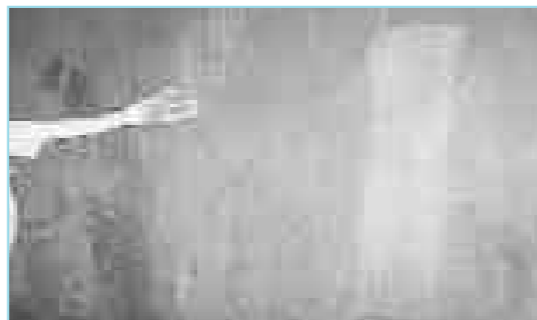
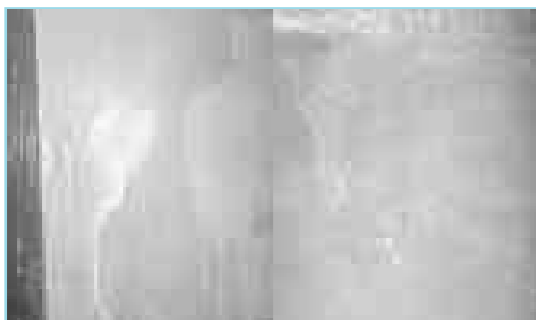
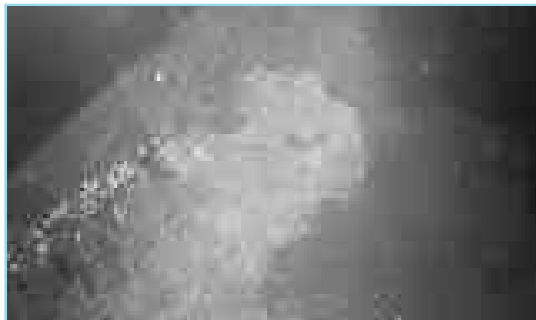

가



1 2.3 &

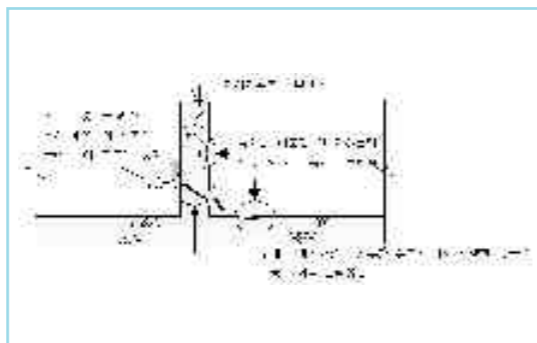

1 ()
(,)
()
, COLD JOINT, FORM TIE,
EPOXY INJECTION
2 ~ 3cm

5 ~ 30 , 80% , 가



가 가 가

FRP, SMC, STS

가 가

가

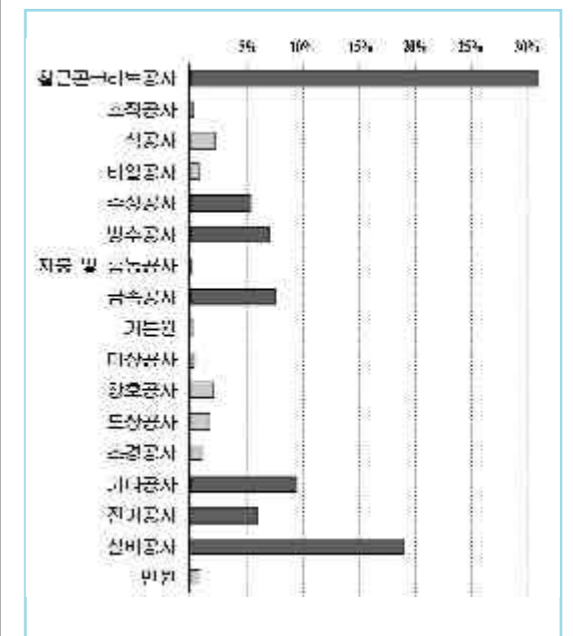

2000

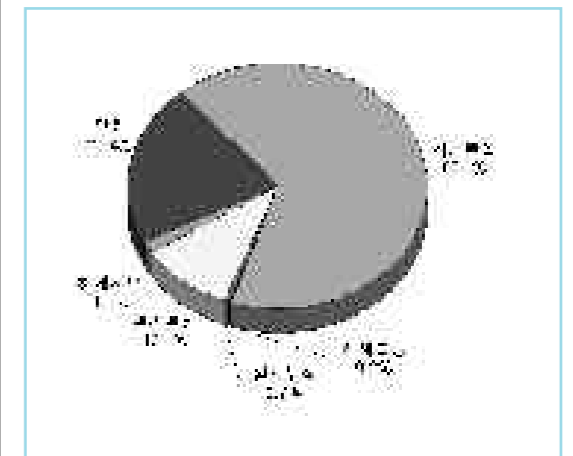

2000