

# Trouble

## 2-ARCH

| 02)3433-7774 | hcb@mail.ssyenc.co.kr

가 , 2 가  
 Sheet  
 Sheet Asphalt , Poly  
 Ethylene( , HDPE), Ethylene Asphalt  
 ( , ECB ), Bentonite Sheet 가 가  
 Sheet  
 ECB Sheet

1. 2  
 (1) ( , R/B )  
 (2) ECB  
 (3) ECB Sheet  
 - ECB Sheet ( )  
 - ECB Sheet  
 - 10cm (Air Channel)  
 Air Test가가  
 (4) ECBSheet Test  
 - Air Test : Sheet  
 - Vaccume Test : Sheet Test  
 (5) Hole Drain

가 6-6

1. Sheet

1.1

NATM

(2) ROCK BOLT 가  
 BOLT , 10cm  
 Sheet  
 ,가 BOLT 가

JOIN

가  
 가  
 Sheet  
 Sheet  
 Sheet  
 Sheet  
 Sheet 가  
 Sheet  
 Sheet

2. 2-ARCH

2.1

2-ARCH

가

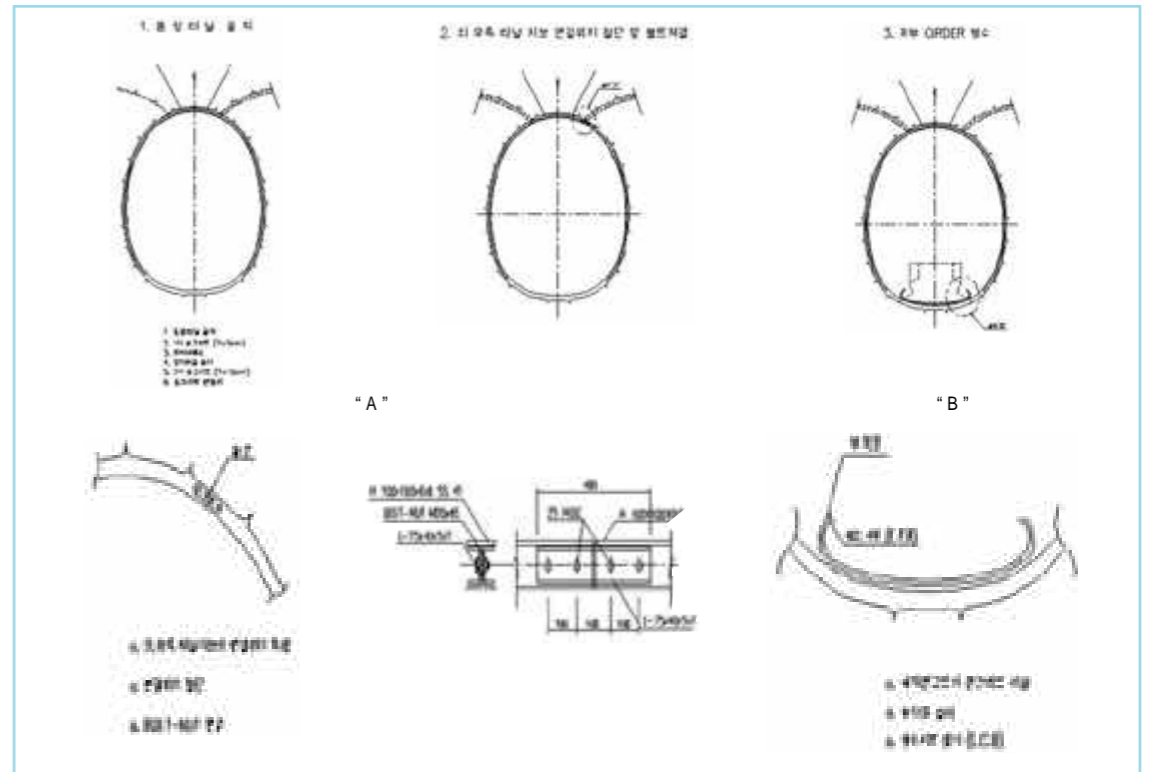

[ 1] 1 2 3

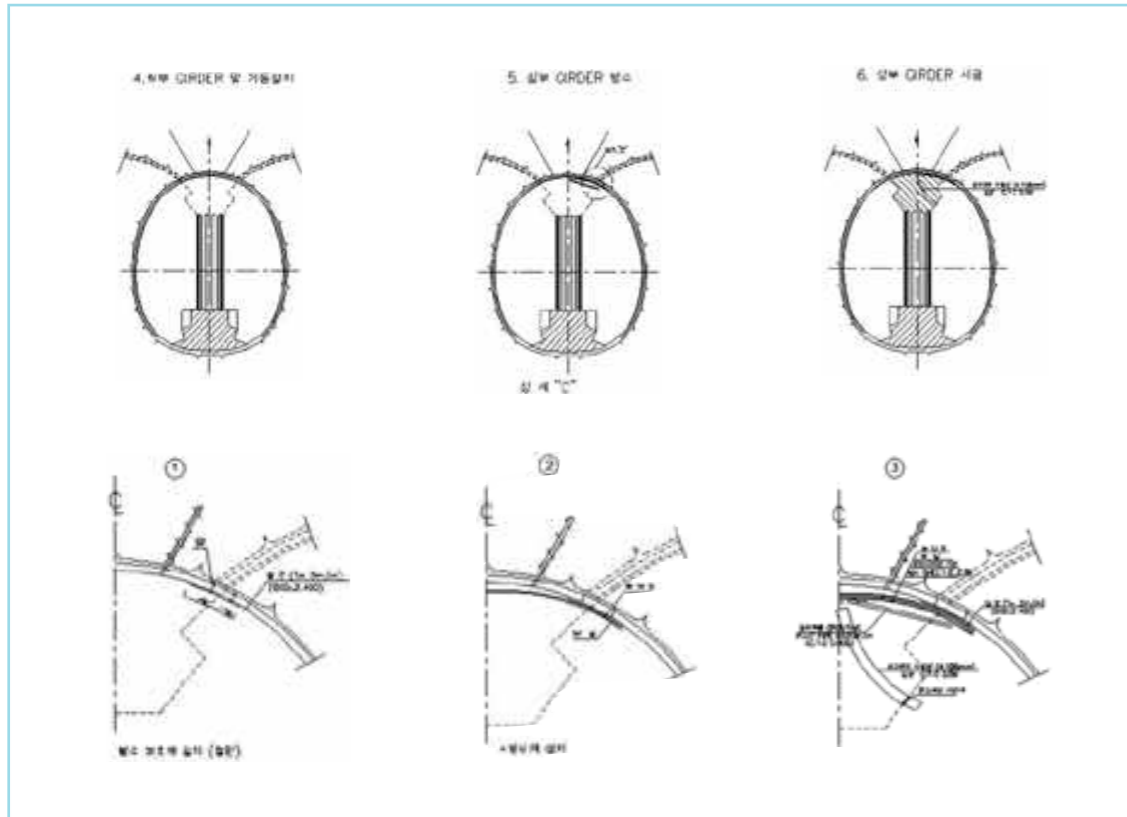

[ 2] 4 5 6

Sheet	,	, 2-ARCH
Sheet	( . )	PIPE
Sheet	C.T.C 5.0M	.
Sheet	2. 2. 가	.
Sheet	가.	.
가 가		
2-ARCH		
가 가		
가		

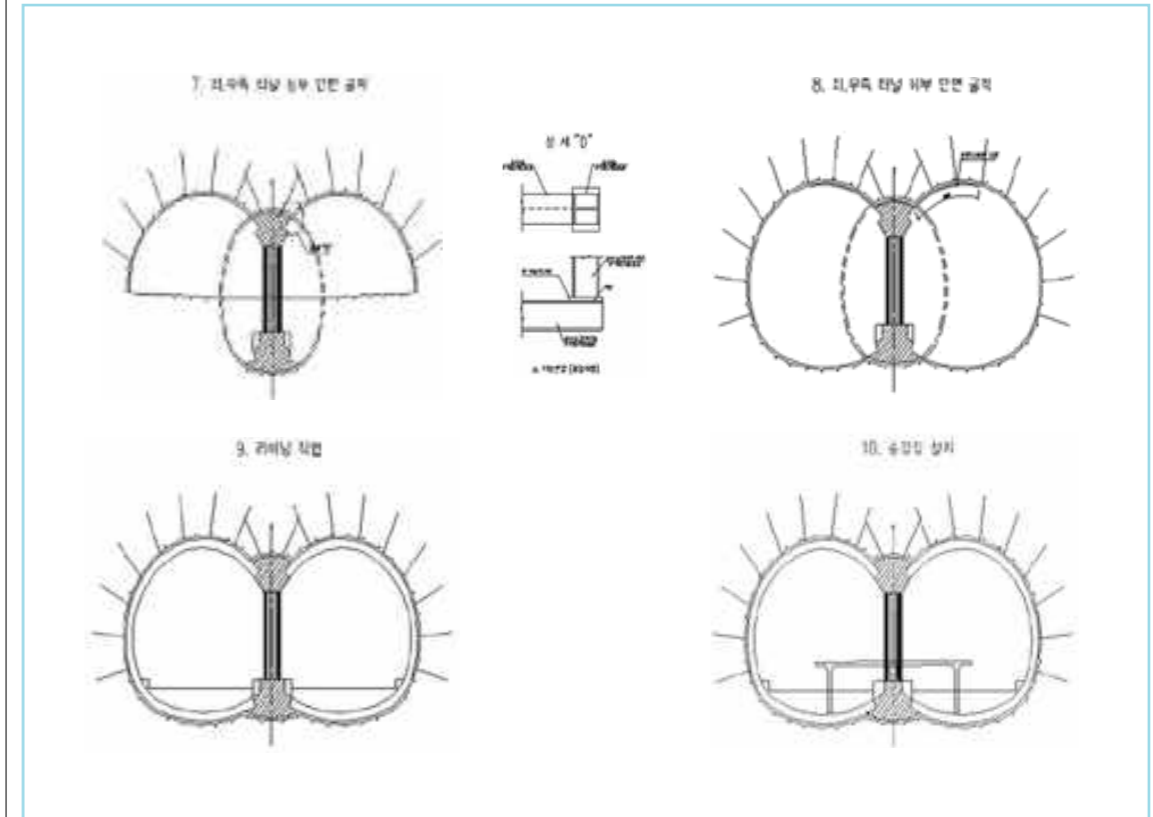

[ 3] 7 8 9 10

20cm	,	Sheet
.	Sheet	가
Sheet		BENT-UP
THP	가	.
Sheet	(Sheet .)	.
Sheet		
2mm	,	Sheet
.	가	.

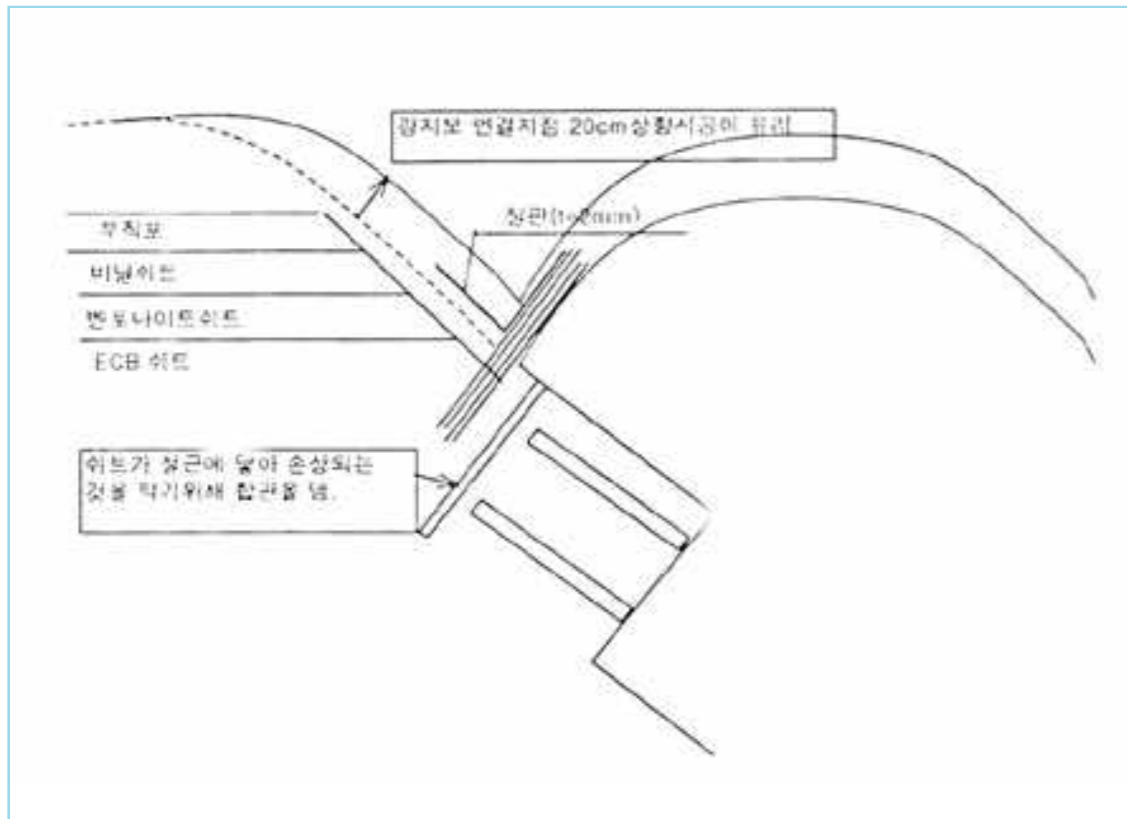

[ 4]

Sheet  
 (2~5mm)  
 2 ( :1mm)  
 Sheet ?  
 Sheet ( )  
 가 )  
 가

2-Arch  
 가  
 2-Arch  
 JOIN  
 가  
 2-Arch

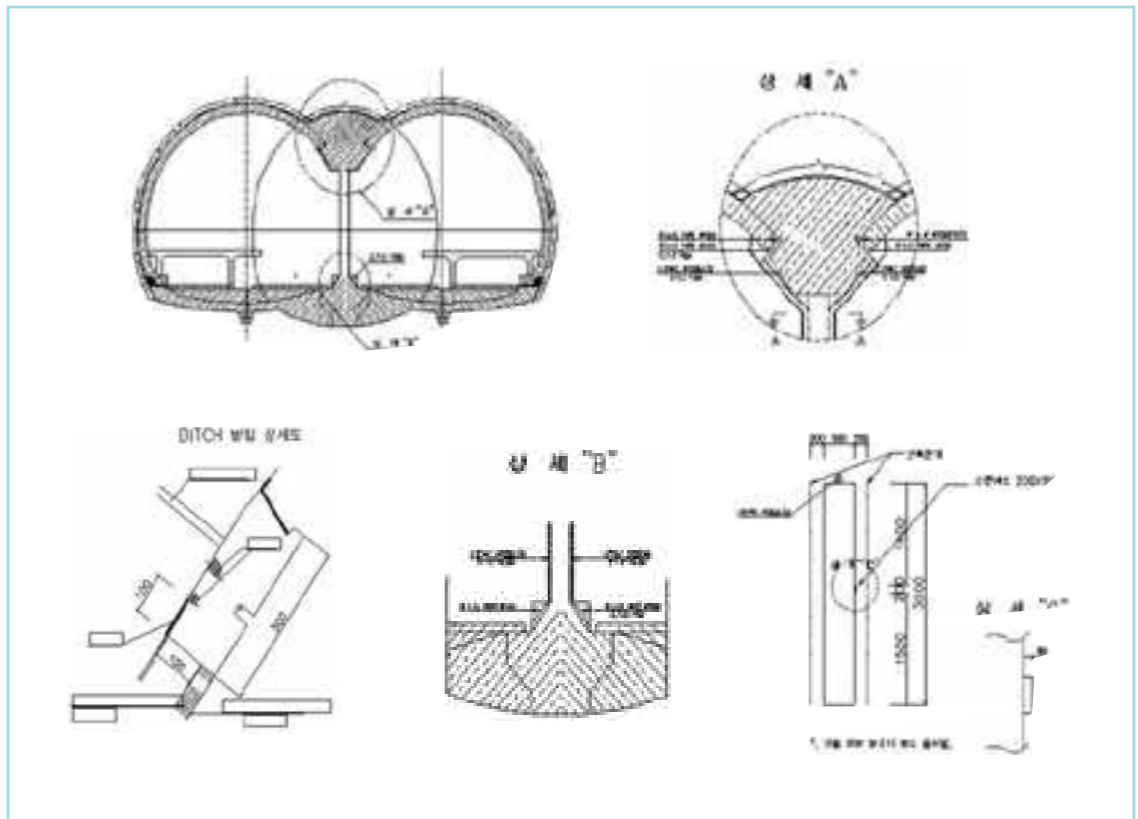

[ 5] 2-ARCH

가 가  
 2-Arch  
 Sheet  
 가

1999, PP. 79~94  
 3. 가 "NATM" , 1981, PP. 179~181  
 4. , 1985,  
 5. , 6 6-4 ( )  
 , 1994  
 6. Meland, O" Underground openings for public use - some results from the research programme for the Gjovik Olympic Mountain Hall", Tunnelling and Ground Conditions, Abdel Salam, 1994 , PP. 49~57  
 7. , 1997

1. " 5-42 Box  
 ; 1997.5  
 2. " ( '1999