

Tel : 02)2252-1487 FAX : 02)2237-4851



1.

3-4

가 가 ,

2.

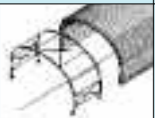
[1]

[1]		
STEEL RIB	BEAM	
		

	Steel Rib Steel Rib 가 Steel Rib (S/R) (S/R)	가 Steel Rib 가 Steel Rib Beam Beam	
	가 S/R가 가 S/R 가 S/R 가 S/R	Beam 가 . 가)	(가)
			가 가
	6.2 cm	7.4 cm	-
* Steel Rib ; H-300x300x10x15, Beam ; H-100x100x6x8, ; 0,11 ton/m			

3.

1)

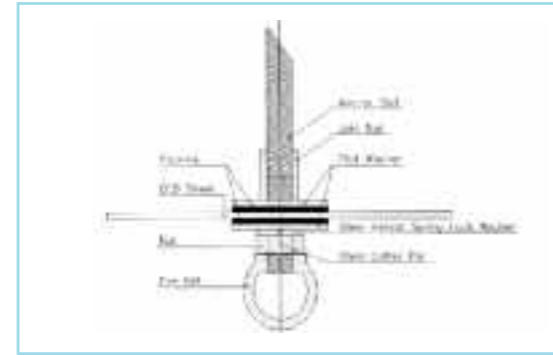

2)

: 14mm x 11cm , 25mm x 3cm

:
: Anchor Bolt

: 20 1

ECB
Test

4.

1)

2)

100%

3)

4)

Tester

5)

가

6)

가

5.

1) Anchor Bolt Test
Anchor Bolt

Shotcrete Anchor Bolt 가
TEST

2) Anchor Bolt
Anchor Bolt

가
Joint Nut
가
Plange

가 Plange
Shotcrete

3) Anchor Bolt
Anchor Bolt Test

Shotcrete
가 5

4) Anchor Bolt

5)

, 100% Test